

**Part Number: PU060-08S15-P1**

**Kit Contents**

Item #	Quantity Reqd.	Description
1	1	Front Passenger Side Mudguard
2	1	Front Driver Side Mudguard
3	1	Rear Passenger Side Mudguard
4	1	Rear Driver Side Mudguard
5	2	Hardware Kit
6	1	Instruction Sheet (Electronic Copy)

**Hardware Bag Contents**

Item #	Quantity Reqd.	Description
1	6	#10 x 15 mm Screws (short)
2	4	#10 x 19 mm Screws (long)
3	6	#10 Spring Clips (short)
4	2	#10 Spring Clips (long)

**Additional Items Required For Installation**

Item #	Quantity Reqd.	Description
1		
2		
3		

**Conflicts**

--

**Recommended Tools**

<b>Personal &amp; Vehicle Protection</b>	<b>Notes</b>
None	
<b>Special Tools</b>	<b>Notes</b>
None	
<b>Installation Tools</b>	<b>Notes</b>
Screwdriver	Phillips #2 & 3, Flat Blade
Drill	Standard/Right Angle
Drill Bits	2.5 mm ( 3/32" ) 6 mm ( 1/4" )
Clean Cloth/Rag	
<b>Special Chemicals</b>	<b>Notes</b>
Soap & Water Mixture	

**General Applicability**

--

**Recommended Sequence of Application**

Item #	Accessory
1	
2	
3	

\*Mandatory

**Vehicle Service Parts** (may be required for reassembly)

Item #	Quantity Reqd.	Description
1		
2		
3		

**Legend**

 **STOP:** Damage to the vehicle may occur. Do not proceed until process has been complied with.

 **OPERATOR SAFETY:** Use caution to avoid risk of injury.

 **CAUTION:** A process that must be carefully observed in order to reduce the risk of damage to the accessory/vehicle and to ensure a quality installation.

 **TOOLS & EQUIPMENT:** Used in Figures calls out the specific tools and equipment recommended for this process.

 **REVISION MARK:** This mark highlights a change in installation with respect to previous issue.

 **SAFETY TORQUE:** This mark indicates that torque is related to safety.

Care must be taken when installing this accessory to ensure damage does not occur to the vehicle. The installation of this accessory should follow approved guidelines to ensure a quality installation.

These guidelines can be found in the "Accessory Installation Practices" document.

This document covers such items as:-

- Vehicle Protection (use of covers and blankets, cleaning chemicals, etc.).
- Safety (eye protection, rechecking torque procedure, etc.).
- Vehicle Disassembly/Reassembly (panel removal, part storage, etc.).
- Electrical Component Disassembly/Reassembly (battery disconnection, connector removal, etc.).

Please see your Toyota dealer for a copy of this document.

**1. Prepare to Mount the Front Mudguards.**

(a) Clean and degrease the front body panel on the driver's side where the splash guard will be located with a clean cloth and soap/water mixture.

(b) Remove the existing screws, locations A and B (Fig. 1-1). DO NOT DISCARD THEM.

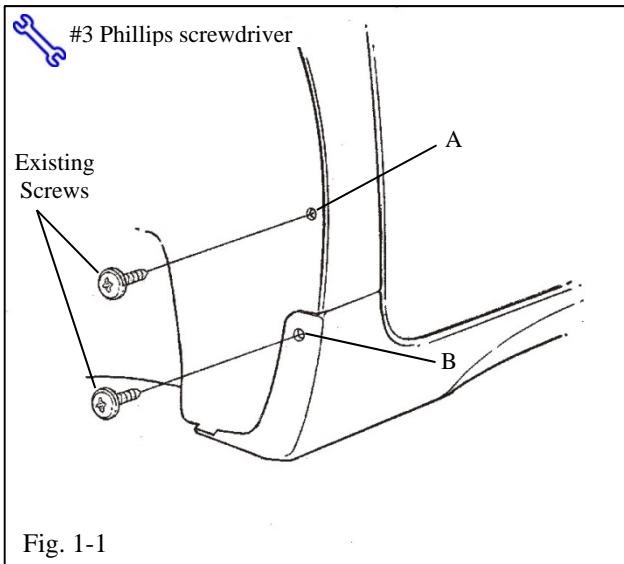
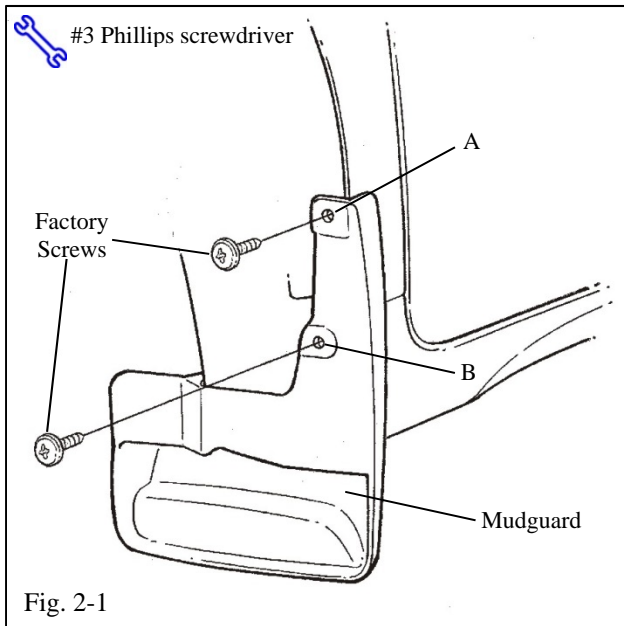

Fig. 1-1

## 2. Install the Front Mudguards.

- (a) Hold the part up and into the body panel.
- (b) Reinstall the OE screws in location A and B (Fig. 2-1).



- (c) Hold the part in position and drill a 2.5mm (3/32") pilot hole in location C (Fig. 2-2).
- (d) Hold the part into the body panel and install a supplied 19mm (long) self-tapping screw into location C (Fig. 2-2).
- (e) Repeat Steps 1 and 2 on the passenger's side.

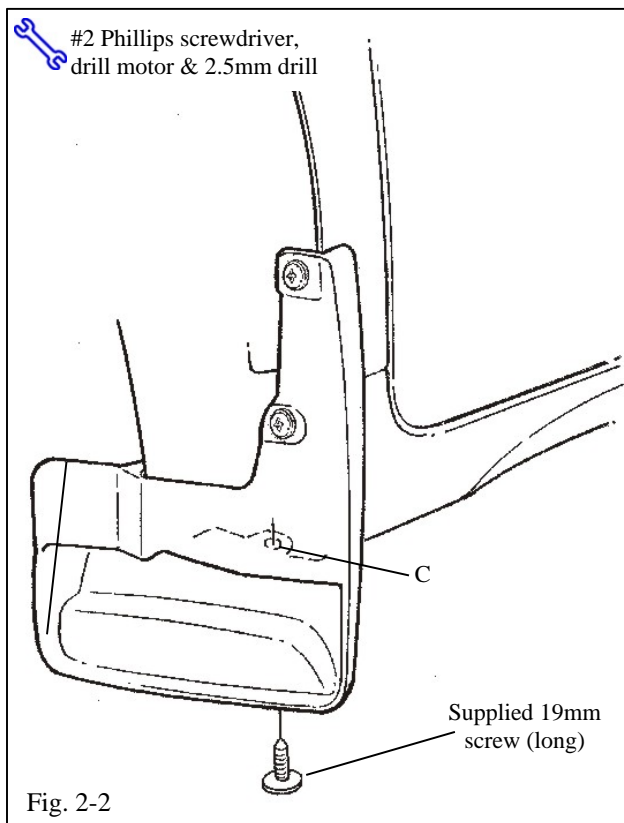

## 3. Prepare to Mount the Rear Mudguards.

- (a) Clean and degrease the rear body panel on the driver's side where the splash guard will be located with a clean cloth and soap/water mixture.

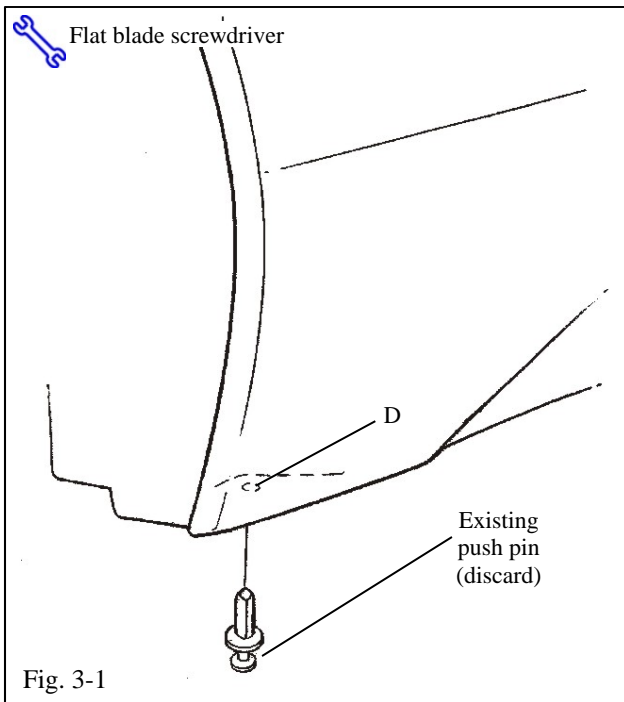

- (b) Remove the existing push pin, location D, and discard it (Fig. 3-1).

#### 4. Install the Rear Mudguards.

- (a) Hold the part up and into the body panel.
- (b) Use the part as a template and drill 6mm (1/4") holes in the panel edge at locations A, B and C (Fig. 4-1).

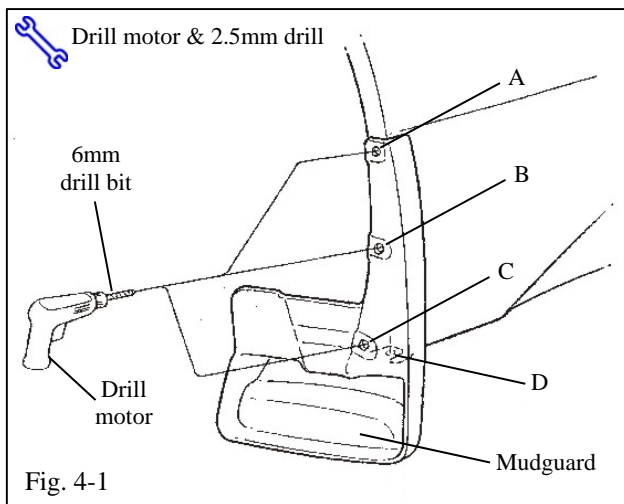

**⚠ NOTE:** Make sure the mudguard is seated in the correct position before drilling. If the holes are too low, gapping will occur.

**NOTE:** For easier accessibility, the wheels can be removed or use a right-angle drill motor.

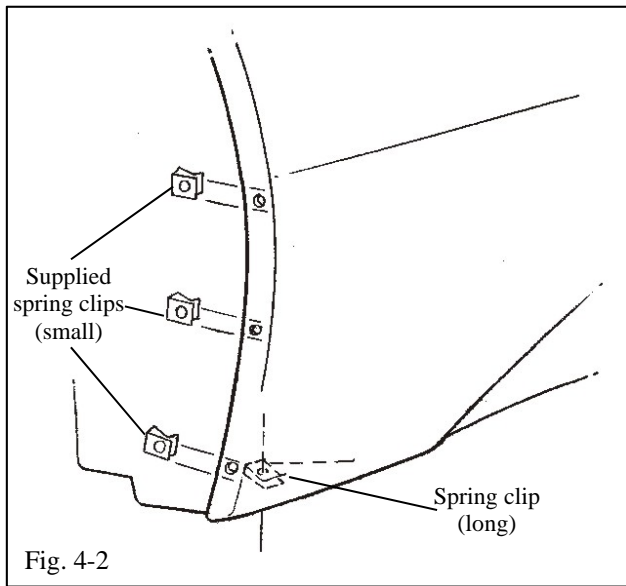

(c) Install the supplied spring clips (small) over the panel edge holes at location A, B and C (Fig. 4-1 & Fig. 4-2).

**NOTE:** The turned up edge goes on the inside of the panel.

(d) **Driver's Side:** Pull the rear liner down and install a supplied spring clip (long) over the panel edge hole at location D (Fig. 4-1 & Fig. 4-2).

**NOTE:** The turned up edge goes on the inside of the panel.

(a) **Passenger's Side:** Install a supplied spring clip (long) over the panel and liner edge hole at location D (Fig. 4-1 & Fig. 4-2).

**NOTE:** The turned up edge goes on the inside of the panel.

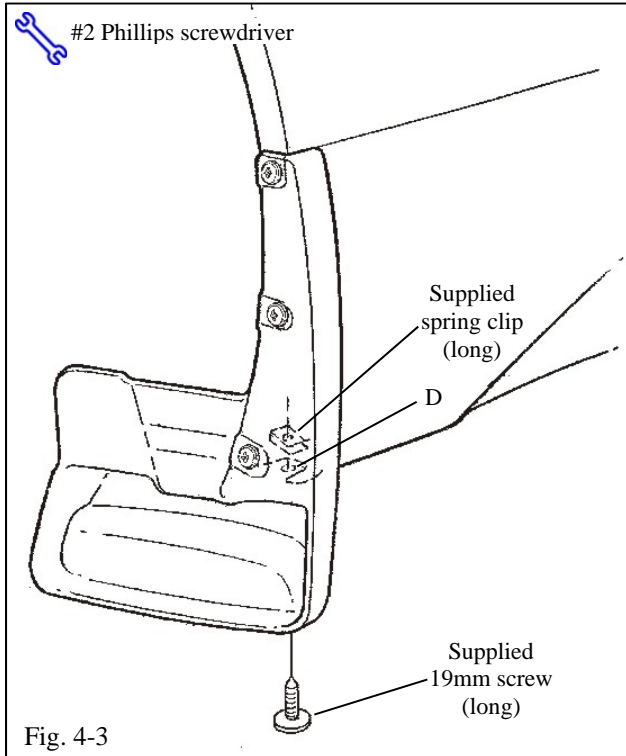

(b) Hold the mudguard up and into the body panel and install the supplied 19mm (long) screw in location D (Fig. 4-3).

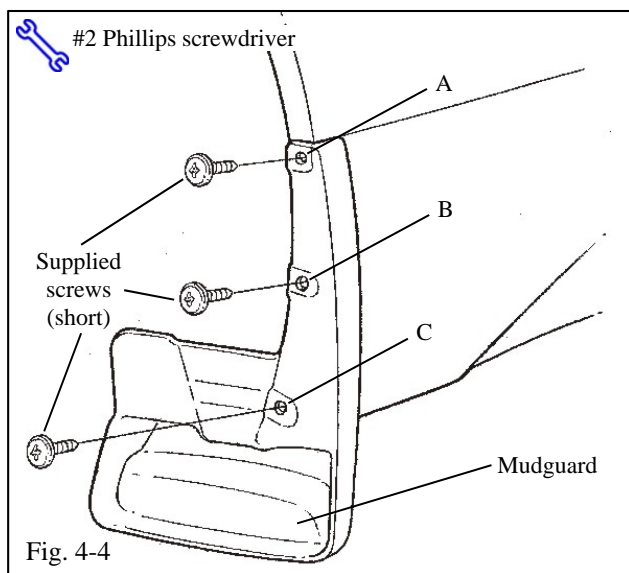

- (c) Hold the mudguard up and into the body panel and install the supplied 15mm (short) screws in locations A, B and C (Fig. 4-4).
- (d) Repeat Steps 3 and 4 on the passenger's side.

Checklist - these points **MUST** be checked to ensure a quality installation.

<u>Check:</u>	<u>Look For:</u>
<p><u>Accessory Function Checks</u></p> <ul style="list-style-type: none"><li><input type="checkbox"/> Gap between the mudguard and the body</li><li><input type="checkbox"/></li><li><input type="checkbox"/></li><li><input type="checkbox"/></li></ul>	<p>Excessive gaps greater than 1.0 mm</p>
<p><u>Vehicle Function Checks</u></p> <ul style="list-style-type: none"><li><input type="checkbox"/></li><li><input type="checkbox"/></li><li><input type="checkbox"/></li></ul>	
<p><u>Vehicle Appearance Check</u></p> <ul style="list-style-type: none"><li><input type="checkbox"/> After accessory installation and removal of protective cover(s), perform a visual inspection.</li></ul>	<p>Ensure no damage (including scuffs and scratches) was caused during the installation process. (For PPO installations, refer to TMS Accessory Quality Shipping Standard.)</p>